

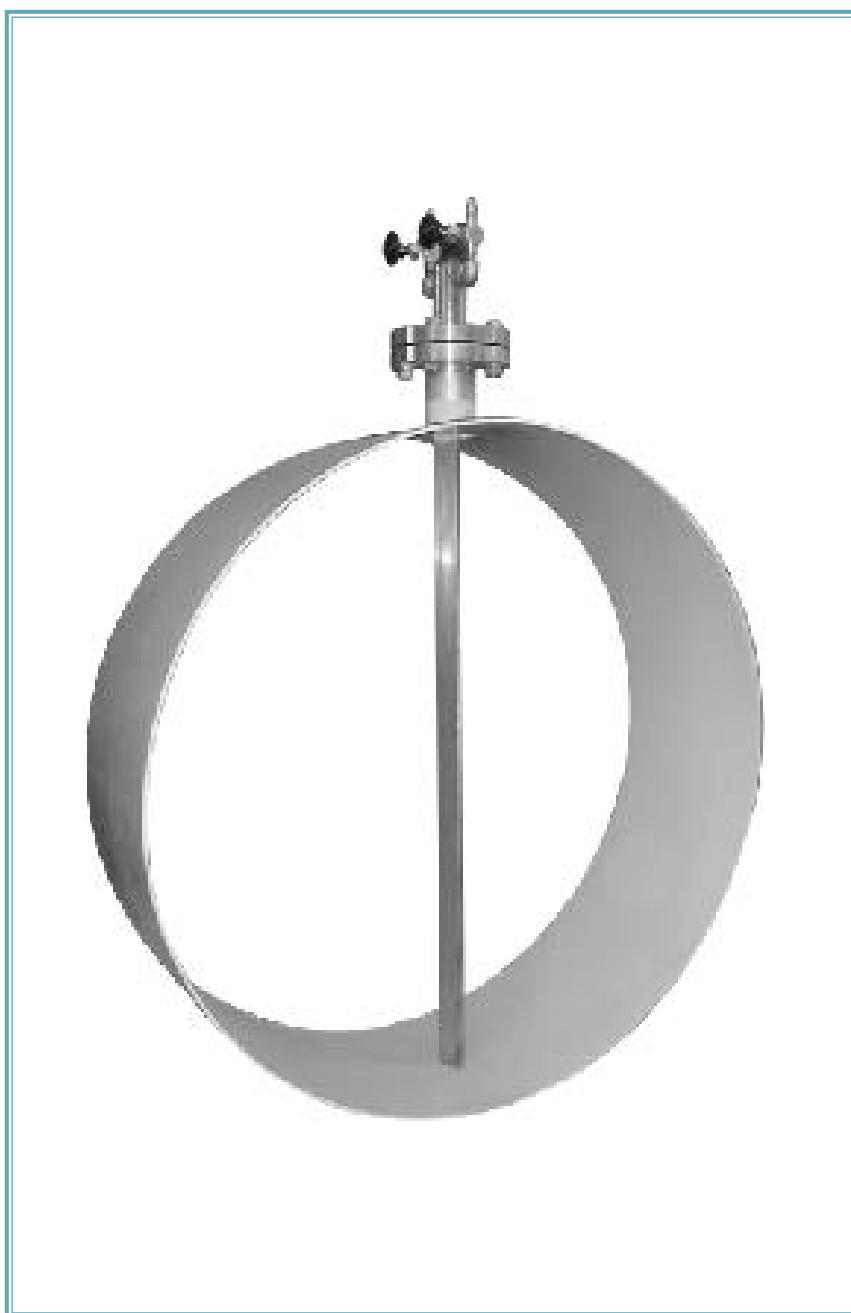

*General Information*

# HAPT-1(2)F

Averaging Pitot Tube  
Flow Sensor



Hitbar Sensor  
Hitbar

가  
가

0(Zero)  
(Stagnation pressure)  
pressure)  
pressure)

(Static  
(Dynamic

$$P_{tot} = P_{stat} + P_{dyn}$$

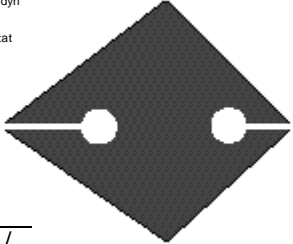
$$P = P_{tot} - P_{stat}$$

$$V = \sqrt{2 p / \rho}$$

**Hitbar Sensor**

Cone  
Sensor  
Sensing port

(HAPT-1F)

Pipe Size	Sensor Size : 1		
	P	GPM	SCFM
2	185	230	880
3	105	390	1500
4	70	560	2100
6	40	970	3700

SCFM : Air 14.73 Psia, 60 F  
GPM : Water 60 F, SG=1.0  
P : Inch of water column

(HAPT-2F)

Pipe Size	Sensor Size								
	1 "			1 1/2 "			2 "		
	DP	GPM	SCFM	DP	GPM	SCFM	DP	GPM	SCFM
2 "	1200	590	2200						
3 "	590	940	3500						
4 "	370	1200	4900						
6 "	1800	2000	8000	600	3700	14000			
8 "				370	5100	19000			
10 "				250	6600	25000			
12 "				180	8000	31000	30	12000	47000
14 "				150	9000	34500	360	13500	53000
16 "				115	10500	40000	280	16000	62000
18 "				95	12000	46500	220	18000	71000
20 "				75	13500	53000	180	21000	81000
24 "				55	15000	65000	130	26000	100000
30 "				35	22000	84000	85	34000	130000
36 "				25	27000	100000	60	42000	160000
42 "				20	32000	120000	45	50000	190000
48 "							35	59000	255000
60 "							25	725000	285000
72 "							15	91000	345000

SCFM : Air 14.73 Psia, and 60 F  
GPM : Water 60 F, SG=1.0  
DP : Inch of water column

	, ,
	STS 316, 304
	Option : STS 316L, Monel
	DN 50      DN 1800(2 to 72)
	(                                      )
	(                                      )
	300
	Option :      600
	10 kgf/cm <sup>2</sup>
	Option : 150 kgf/cm <sup>2</sup>
	± 1.0% FS
	± 0.1% FS
	10 : 1(                                      가 )



- \*                                      가                                      .
- \* Mounting Hardware                                      가                                      .
- \*                                      가                                      .
- \*                                      가                                      .
- \*                                      가                                      .



- \*                                      HAPT-(1)2F                                      HAPT-(1)2F                                      .
- 3-Way      5-Way Valve                                      3-Way      5-Way Valve



(Pt 100 )

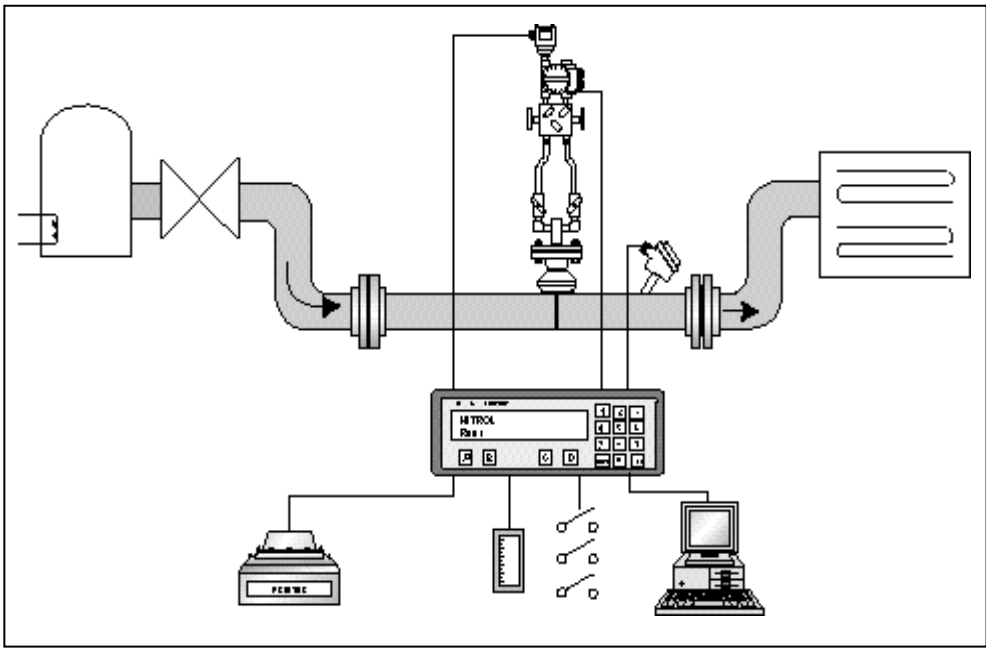

**Assembly Parts**

**HAPT Instrument Valve**

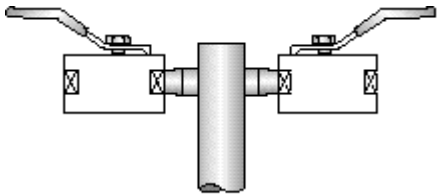
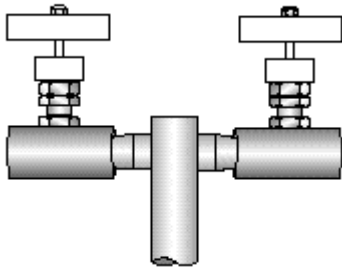
Schematic diagram	Description	Material
	Ball valve 1/2 NPT max. 85 bar at 40 16 bar at max. 230	CS 316SS
	Ball valve 1/4 NPT max. 85 bar at 40 16 bar at max. 230	CS 316SS
	Shut-off valve 1/4 NPT max. 85 bar at 40 16 bar at max. 230	CS 316SS
	Shut-off valve 1/2 NPT max. 400 bar at 90 270 bar at max. 240	CS 316SS

**HAPT Mounting Hardware**

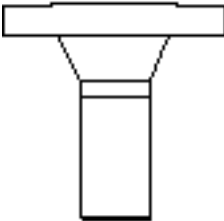
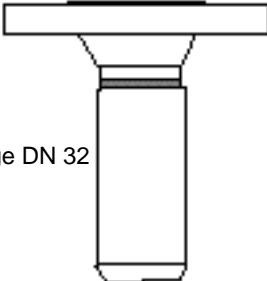
HAPT-1F		HAPT-1F	
Without assembly parts	MH 01	Without assembly parts	MH 11
With assembly parts material CS(Standard)	MH 02	With assembly parts material CS(Standard)	MH 12
With assembly parts material 316	MH 03	With assembly parts material 316	MH 13
 <p>Flange DN 25</p>		 <p>Flange DN 32</p>	

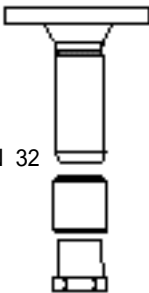
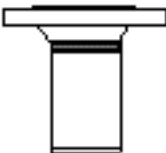
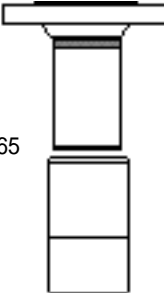
HAPT-2F		HAPT-1F		HAPT-2F	
Without assembly parts	MH 21	Without assembly parts	MH 31	Without assembly parts	MH 41
With assembly parts material CS(Standard)	MH 22	With assembly parts material CS(Standard)	MH 32	With assembly parts material CS(Standard)	MH 42
With assembly parts material 316	MH 23	With assembly parts material 316	MH 33	With assembly parts material 316	MH 43
 <p>Flange DN 32</p>		 <p>Flange DN 65</p>		 <p>Flange DN 65</p>	

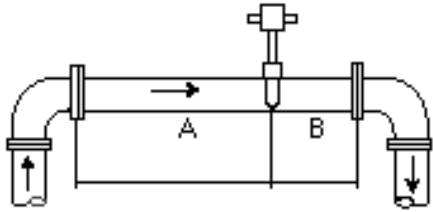
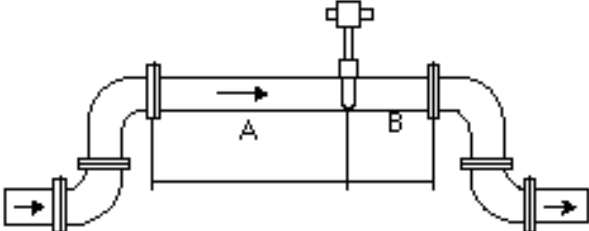
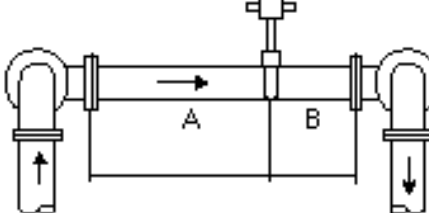
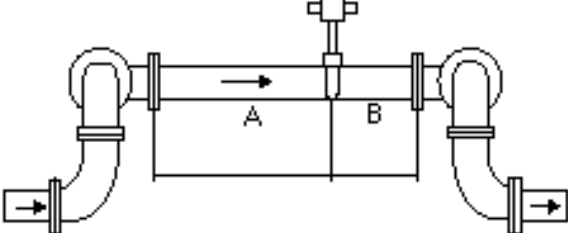
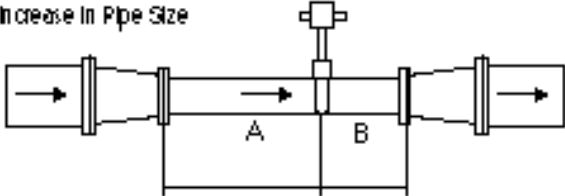
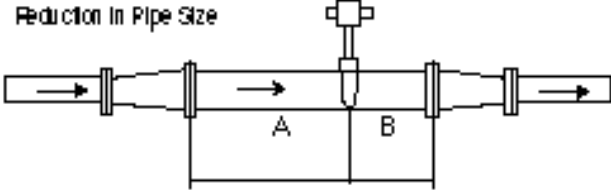
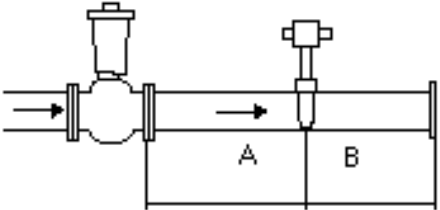
	Upstream dimension(A)	Downstream dimension(B)
	<b>7</b>	<b>3</b>
	<b>9</b>	<b>3</b>
	<b>17</b>	<b>4</b>
	<b>18</b>	<b>4</b>
<p>Increase in Pipe Size</p> 	<b>7</b>	<b>3</b>
<p>Reduction in Pipe Size</p> 	<b>7</b>	<b>3</b>
<p>Control valve</p> 	<b>24</b>	<b>4</b>

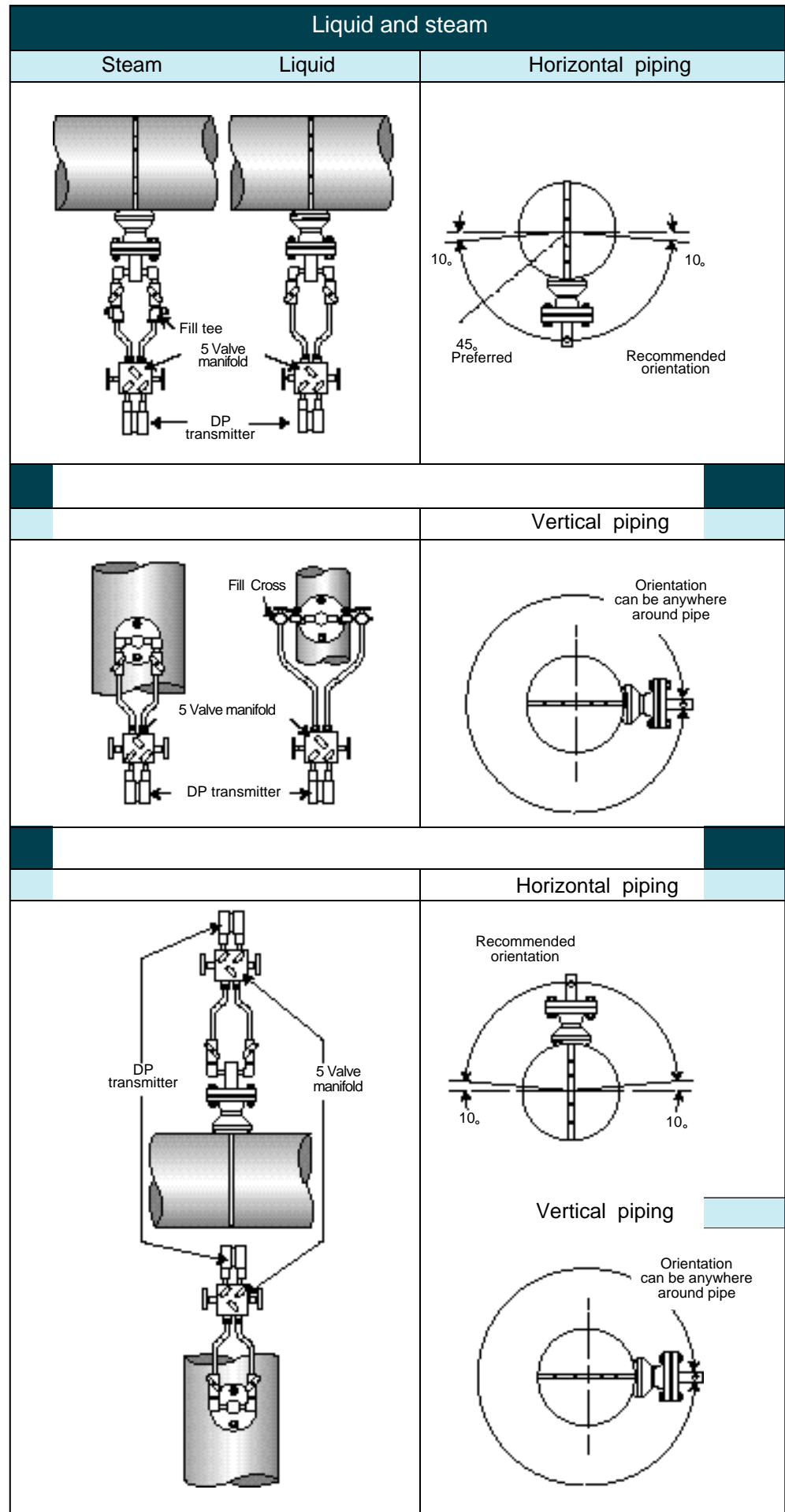

Flow Parameter

가

Tag No.			
Flow parameter			
Max. Flow Rate(m <sup>3</sup> /h)			
Min. Flow Rate(m <sup>3</sup> /h)			
Max. Temperature( )			
Max. Pressure(psia)			
Pipe Inside Diameter(mm)			
Density(kg/m <sup>3</sup> )			
Viscosity(cP)			

가 ,

Tag No.			
Flow parameter			
Max. Flow Rate(m <sup>3</sup> /h)			
Min. Flow Rate(m <sup>3</sup> /h)			
Max. Temperature( )			
Max. Pressure(psia)			
Pipe Inside Diameter(mm)			
Density(kg/m <sup>3</sup> )			
Viscosity(cP)			

## ORDER CODES

\* 1F : Single Support  
2F : Double Support

\* Process Connection Size(Flange)  
A(Rating) : 1 ANSI(150#, 300#, 600#, 900#)  
B(Rating) : 1 1/2 ANSI(150#, 300#, 600#, 900#)  
C(Rating) : 2 ANSI(150#, 300#, 600#, 900#)  
D(Rating) : 3 ANSI(150#, 300#, 600#, 900#)  
E(Rating) : 4 ANSI(150#, 300#, 600#, 900#)  
O(Rating) : Others

\* Sensor Size  
A : 1  
B : 1 1/2 "  
C : 2  
O : Others

\* Process Pipe Size  
02 : 2  
03 : 3  
04 : 4  
06 : 6  
} }  
72 : 72  
00 : Others

\* Sensor Materials  
A : STS 304  
B : STS 316  
C : STS 316L  
D : Monel  
E : Inconel  
O : Others

\* Valve Mat 1  
1 : C.S  
2 : STS 304  
3 : STS 316  
4 : STS 316L  
5 : Monel

\* Valve Type  
A : Ball Valve  
B : Shut-off Valve

HAPT-1(2)F - \*\* \*\* \*\* \*\*



62-182

: (031) 943-0875~7 (02)744-9922

: (031) 943-0878, 5600

<http://www.hitrol.co.kr>

[hitrol@hitrol.co.kr](mailto:hitrol@hitrol.co.kr)